

**In-Line Flasher with Hideaway Undercover LED Heads**



**LDHF301 Series**

*In-Line Flasher with Detachable  
Unidirectional LED Head*



**LDHF311 Series**

*In-Line Flasher with Detachable  
Spherical LED Head*



---

**Star Headlight & Lantern Co., Inc.**  
455 Rochester Street Avon, NY 14414 Phone: 585-226-9787 FAX: 888-478-2797  
**STAR** **STAR** **STAR SIGNAL** **BRADFORD** [www.starheadlight.com](http://www.starheadlight.com)  
125 YEARS SINCE 1889 **WARNING SYSTEMS** **VEHICLE PRODUCTS** **Vehicle Solutions**

### NOTICE

Due to continuous product improvements, we must reserve the right to change any specifications and information, contained in this manual at any time without notice. Star Headlight & Lantern Co., Inc. makes no warranty of any kind with regard to this manual, including, but not limited to, the implied warranties of merchantability and fitness for a particular purpose. Star Headlight & Lantern Co., Inc. shall not be liable for errors contained herein or for incidental or consequential damages in connection with the furnishing, performance, or use of this manual.



**This device may be regulated by Federal, State, and/or Local ordinances. These devices may be used ONLY on approved vehicles. It is the sole responsibility of the user to ensure compliance.**



This light utilizes high-intensity LED Lamps. DO NOT stare directly into the light while it is on, as momentary blindness and/or permanent eye damage may occur.

**IMPORTANT: Please read all of the following instructions before installing your new light. Failure to follow these safety precautions may result in damage to your light or vehicle and may result in serious injury or death to you and your passengers.**

## Models and Parts

| <b><u>Model Number</u></b> | <b><u>Description</u></b>   |
|----------------------------|---|
| LDHF301-W-10               | In-Line Flasher with Detachable Unidirectional LED Head and 10-foot cable |
| LDHF301-W-30               | In-Line Flasher with Detachable Unidirectional LED Head and 30-foot cable |
| LDK311-W-10                | In-Line Flasher with Detachable Spherical LED Head and 10-foot cable      |
| LDK311-W-30                | In-Line Flasher with Detachable Spherical LED Head and 30-foot cable      |

**Each "W" kit will also include one corresponding filter of each color (Clear, Amber, Blue, and Red):**

|          |  |
|----------|--|
| LSF300-* | Colored Filter for Unidirectional LED Head (*=color) |
| LSF310-* | Colored Filter for Spherical LED Head (*=color)      |

**Each kit will also include the following:**

|            |   |
|------------|---|
| P4177      | Tie Wrap (QTY=2)  |
| P30052-46  | 5/8" Philips Head Screw (Quantity=2 - for mounting heads) |
| P30047-118 | Gasket for LED Head                                       |

**Optional Cables:**

|         |  |
|---------|--|
| SWH-L4  | 4' Extension Cable for Detachable LED Heads  |
| SWH-L8  | 8' Extension Cable for Detachable LED Heads  |
| SWH-L15 | 15' Extension Cable for Detachable LED Heads |
| SWH-L20 | 20' Extension Cable for Detachable LED Heads |
| SWH-L25 | 25' Extension Cable for Detachable LED Heads |
| SWH-L30 | 30' Extension Cable for Detachable LED Heads |
| SWH-L35 | 35' Extension Cable for Detachable LED Heads |

## **Installation Notes**

**Please Note:** These instructions are provided as a general guideline only. *Some vehicles may require special mounting, wiring, and/or weather-sealing. This is the sole responsibility of the installer.* Star Headlight & Lantern Co., Inc. assumes no responsibility for the integrity of the installation for this or any of its products.

Proper installation of the unit is essential for years of safe, reliable operation. Please read all instruction **before** installing the unit. Failure to follow these instructions can cause serious damage to the unit or vehicle and may void warranties.

- The installer must have a firm knowledge of basic electricity, vehicle electrical systems, and emergency equipment.
- If you need to drill any holes when installing this product, please take care to check that BOTH SIDES of your drilling surface are clear from obstructions, to ensure that you do not damage your vehicle and or pre-existing wiring.
- Controls should be placed within convenient reach of the driver.

### ***Before beginning the installation:***

- Determine where the heads are to be mounted.
- Determine where you will mount the switch.
- Determine if you will be synchronizing your flasher with any other flashers or other synchronizable products.
- Verify that you have a clear path to run your wires between the heads, flasher unit(s), switch, and any other lights that the flasher will be synchronized with.

**Keep These Instructions** - Keep these instructions in the vehicle or other safe place for future reference. Advise the vehicle operator of the location.



- Each LED head has its own in-line flasher.
- The LED light heads must be installed inside an existing light assembly on the vehicle.
- The unidirectional light head on the **LDHF301** must be installed vertically to ensure proper light distribution.
- The spherical light head on the **LDHF311** can be installed in any direction.
- The unidirectional light heads on the **LDHF301** should only be installed in a 1" hole on a **top** or **bottom** surface that allows the base of the head to be **horizontal**.
- **Both** the unidirectional and spherical heads should have 3" diameter **total** clearance inside the housing (allows 1" clearance on all sides of the head).
- The in-line flasher should be secured to the vehicle so that it does not pull on any of the wires.

## **Installation**

1. Establish a location for each in-line flasher unit that is close enough to the location where the LED head will be mounted. The location should have limited exposure to the environment (e.g. trunk, engine compartment, cab, etc.). Use the two tie wraps enclosed to mount the unit, **taking care not to bend the flasher.**
2. Determine a path for the cable from the flasher, keeping in mind that you will have to connect the wires from units that are synchronized with one another.
3. Remove the headlight or taillight assembly according to the vehicle manufacturer's instructions.
4. Find a location on each light assembly that will accommodate proper mounting of the light head as well as not interfere with other components.



***WARNING!! The heat output of the LED head can melt plastic if it is not installed with adequate space around the unit. A minimum of 1" clearance is recommended.***

5. Using a #40 bit, drill your holes according to the diagrams below. *For the LDHF301 heads*, take care to drill the screw holes so that when installed, the heads will be directed out of the corners at a 45° angle (see diagram below).
6. Place a gasket over each head and install the heads using the 5/8" Philips head screws included.
7. Re-assemble the light housings on your vehicle.

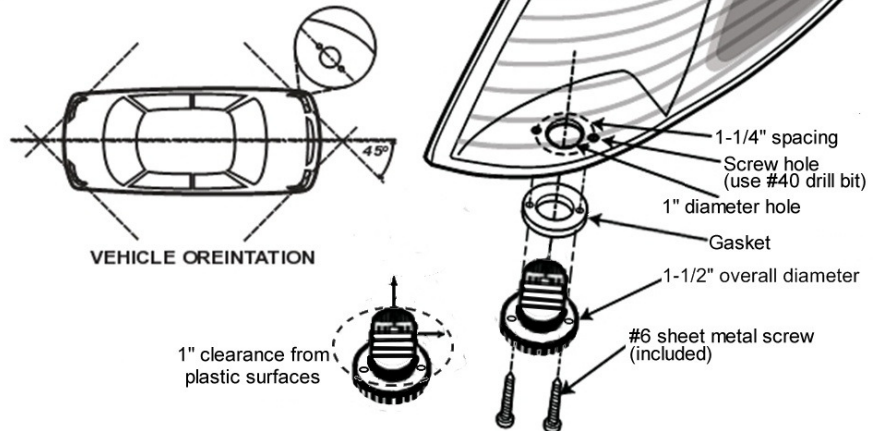

## Wiring



When wiring your LED Kit(s) (and compatible) lights, YOU MUST take the following precautions to eliminate Electromagnetic Interference (EMI).



- The LED modules and the radio (or other sources of EMI) should be kept as far away from each other as possible.
- Separate the radio wires and the LED wires:
  - ▲ *The radio antenna wire should make a right angle from the back of the radio and run down one side of the vehicle.*
  - ▲ *The LED wires should make a right angle out of the back of the switchbox and exit in the opposite direction of the antenna wire and/or radio power wires.*
- Any excess wires should be cut short.
- The Ground wire, Power wire, Synchronization wire, and Pattern Select wire (if used) should be bound tightly together as they run from light to light, through your switchbox, and finally to the battery.
- Do not ground each unit independently to the chassis. Run the ground for each unit as shown below in a "bus" like structure, to the negative terminal on the battery.

**BEFORE installing your lights and running your wires, please review the diagram below showing an example of how the wires should be run.**

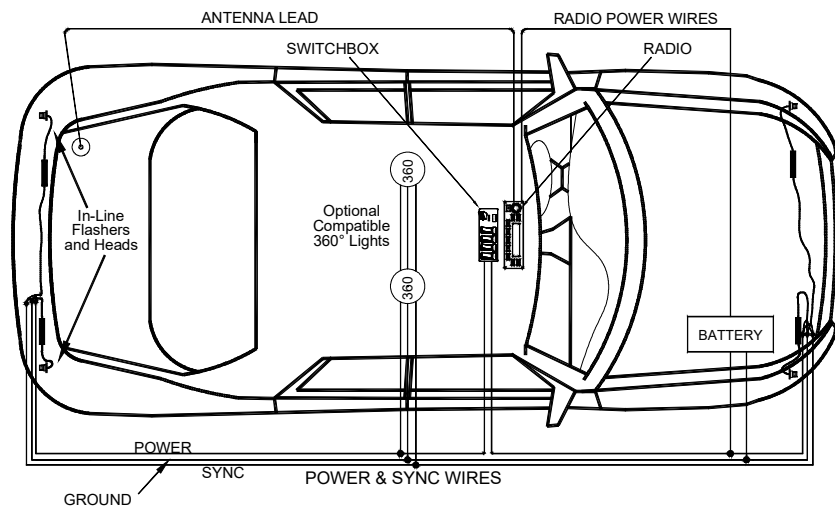

1. Connect the **Black** wire to the negative terminal of your battery.
2. Connect the **Red** wire to your switch that supplies +12-24 VDC.
3. If you are synchronizing two or more flasher units, run the **White** wires along with the **Red** and **Black** wires to each unit (as shown above), but **DO NOT CONNECT THE WHITE WIRES UNTIL PROGRAMMING HAS BEEN COMPLETED** (see next two pages). **Note:** The total distance between the two farthest units should be no more than 40 feet. If you are NOT synchronizing units, cut this wire short and tape it off.
4. The **Green** is used for Pattern Programming (see next page).

**Black: Battery Negative**  
**Red: +12-24 VDC**  
**White: Synchronization**  
**Green: Pattern Select**

# Pattern Programming

This unit has twelve different **Flash Patterns** to select from in each of two different Phases, as well as a Steady Burn Pattern.

1. Power up the unit by connecting the red and black wires.
2. If needed, change the flash pattern by touching and releasing the Green wire to BAT Neg/Ground.
3. After the pattern has been set, tape or place a wirenut over the end of the green wire to prevent it from coming into contact with ground.

| Phase 1 Flash Pattern | Phase 2 Flash Pattern | Pattern Type | Pattern Description  | Shortcuts                                    |
|-----------------------|-----------------------|--------------|----------------------|--|
| 1                     | 13                    | K            | Flicker              | ←  |
| 2                     | 14                    | L            | Fast Doubleflash     | Pattern 1 (Phase 1):<br>3 sec or 1 flash     |
| 3                     | 15                    | M            | Tripleflash          |  |
| 4                     | 16                    | N            | PSU-flicker          |  |
| 5                     | 17                    | O            | PSU Random           | Pattern 13 (Phase 2):<br>9 sec or 3 flashes  |
| 6                     | 18                    | F            | Quadflash            |  |
| 7                     | 19                    | G            | Quadflash w/Post-Pop | Pattern 6 (Phase 1):<br>6 Sec or 2 flashes   |
| 8                     | 20                    | H            | Singleflash          |  |
| 9                     | 21                    | I            | Doubleflash          | Pattern 18 (Phase 2):<br>12 sec or 4 flashes |
| 10                    | 22                    | J            | Delta-Omega          |  |
| 11                    | 23                    | C            | Post Pop             |  |
| 12                    | 24                    | E            | Random               |  |
| NA                    |                       |              | Steady               | 18 Sec/5 Flashes                             |

**Pattern Shortcuts:** Hold Green wire to ground for indicated time.  
**Steady Burn:** Not in pattern cycle. Only accessible through shortcut. Hold Green wire to ground for 18 seconds (light will flash 5 times).

### SYNCHRONIZATION

You can synchronize up to six lights with compatibility.

**DO NOT CONNECT WHITE WIRES UNTIL PROGRAMMING HAS BEEN COMPLETED FOR ALL LIGHTS!!**

1. Power up the first unit and select a Phase 1 pattern. Touch and release the green wire to ground to change patterns.
2. Program the second light with the same **Pattern Type**.  
 Lights with the SAME phase flash together (simultaneous).  
 Lights with DIFFERENT phases flash opposite one another (alternate).
3. After programming all lights, tie off the green wires and connect the white wires together.
4. Test lights by applying power to all of them at the same time.

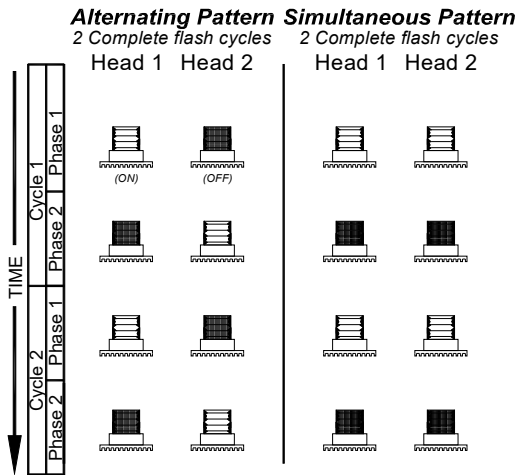

## LED FIVE YEAR LIMITED WARRANTY

The manufacturer warrants this LED light against factory defects in material and workmanship for five years after the date of purchase. The owner will be responsible for returning to the Service Center any defective item(s) with the transportation costs prepaid. The manufacturer will, without charge, repair or replace *at its option*, products, or part(s), which its inspection determines to be defective. Repaired or replacement item(s) will be returned to the purchaser with transportation costs prepaid from the service point. A copy of the purchaser's receipt must be returned with the defective item(s) in order to qualify for the warranty coverage. Exclusions from this warranty include, but are not limited to, domes, and/or the finish. This warranty shall not apply to any light, which has been altered, such that in the manufacturer's judgment, the performance or reliability has been affected, or if any damage has resulted from abnormal use or service.

There are no warranties expressed or implied (including any warranty of merchantability or fitness), which extend this warranty period. **The loss of use of the product, loss of time, inconvenience, commercial loss or consequential damages, including costs of any labor, are not covered.** The manufacturer reserves the right to change the design of the product without assuming any obligation to modify any product previously manufactured.

This warranty gives you specific legal rights. You might also have additional rights that may vary from state to state. Some states do not allow limitations on how long an implied warranty lasts. Some states do not allow the exclusion or limitation of incidental or consequential damages. Therefore, the above limitation(s) or exclusion(s) may not apply to you.

If you have any questions concerning this or any other Star product, please contact our **Customer Service Department** at (585) 226-9787.

If a product must be returned for any reason, please contact our Customer Service Department to obtain a Returned Materials Authorization number (RMA #) before you ship the product to Star. Please write the RMA # clearly on the package near the mailing label.



PROUDLY MADE IN THE USA  
An ISO 9001:2008 Certified Company



**Star Headlight & Lantern Co., Inc.**

455 Rochester Street Avon, NY 14414 Phone: 585-226-9787 FAX: 888-478-2797

**STAR**  
WARNING  
SYSTEMS

**STARSIGNAL**  
VEHICLE PRODUCTS

**BRADFORD**  
Vehicle Solutions

[www.starheadlight.com](http://www.starheadlight.com)

