

REV.	ECR	DESCRIPTION	DATE
-	8079	INITIAL DRAWING REQUEST	12/08/08
A	8464	CHANGED PLIT424 TO PLIT425	7/7/2009

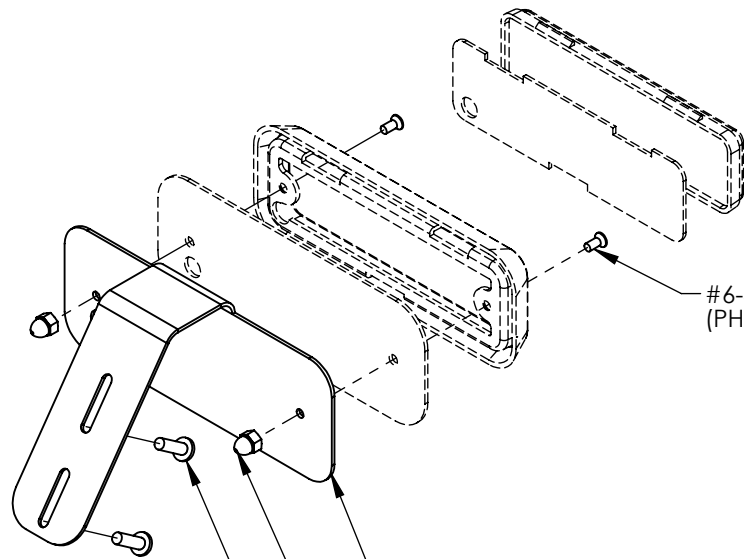

#6-32 X 5/16" MACHINE SCREW
(PHILIPS PFLAT HEAD STAINLESS STEEL)

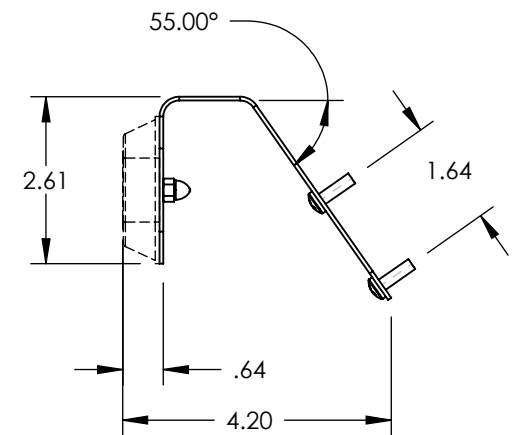
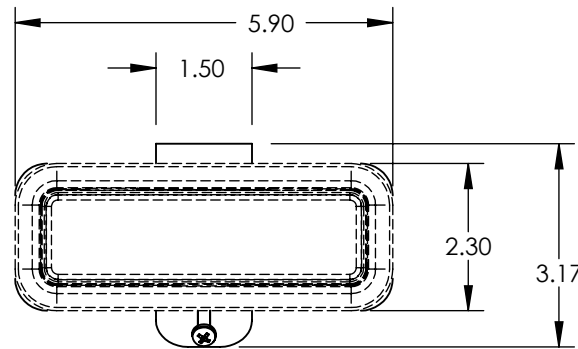

#10 X 5/8 SELF TAP SCREW
(PHILIPS, TYPE 25, STAINLESS)

TRUNK BRACKET
(16 GAGE CRS, BLACK POWDER COAT)

#6 ACORN NUT
(STAINLESS STEEL)

UNLESS OTHERWISE SPECIFIED

DIMENSIONS ARE IN INCHES

TOLERANCES:

ANGULAR: ± 2 DEG.

.X ± .100
.XX ± .020
.XXX ± .005
.XXXX ± .001

RoHS COMPLIANT: Yes

MATERIAL:

N/A

FINISH:

N/A

DRAWN BY: MD

DRAWING APPROVED BY ECR

THE INFORMATION CONTAINED IN THIS DRAWING IS THE SOLE PROPERTY OF STAR HEADLIGHT & LANTERN CO., INC.. ANY REPRODUCTION IN PART OR AS A WHOLE WITHOUT THE WRITTEN PERMISSION OF STAR HEADLIGHT & LANTERN CO., INC. IS STRICTLY PROHIBITED.

STAR HEADLIGHT & LANTERN CO., INC.

455 Rochester St. Avon NY 14414

Ph:(585) 226-9500 Fax: (585) 226-2029

MODEL: 274-DLXT-T

TITLE:

274-DLXT-T MODEL DRAWING

DWG. NO.

274-DLXT-T

REV

A

SCALE: 1:3

DO NOT SCALE FROM DRAWING

SHEET 1 OF 1

NOTES:

- 1) 10X12 POLY BAG (P30024-14)
- 2) BAG LABEL (PLAB21X2WHI)
- 3) INSTRUCTION SHEET (PLIT425)

