

REV.	ECR	DESCRIPTION	DATE
-	8079	INITIAL DRAWING REQUEST	12/08/08
A	8464	CHANGED PLIT424 TO PLIT425	7/7/2009

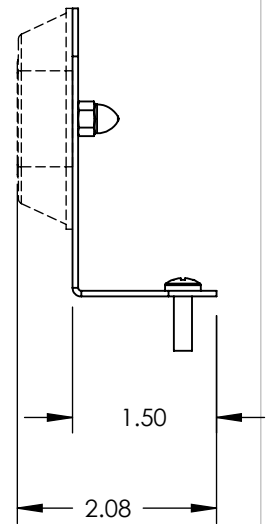
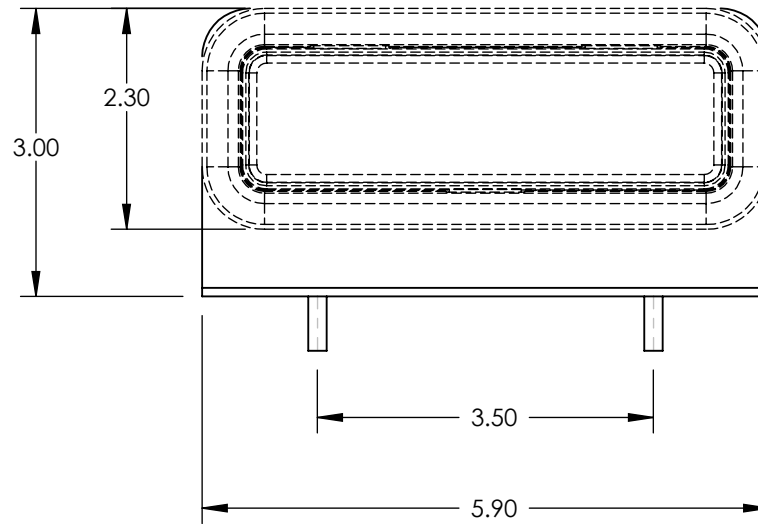
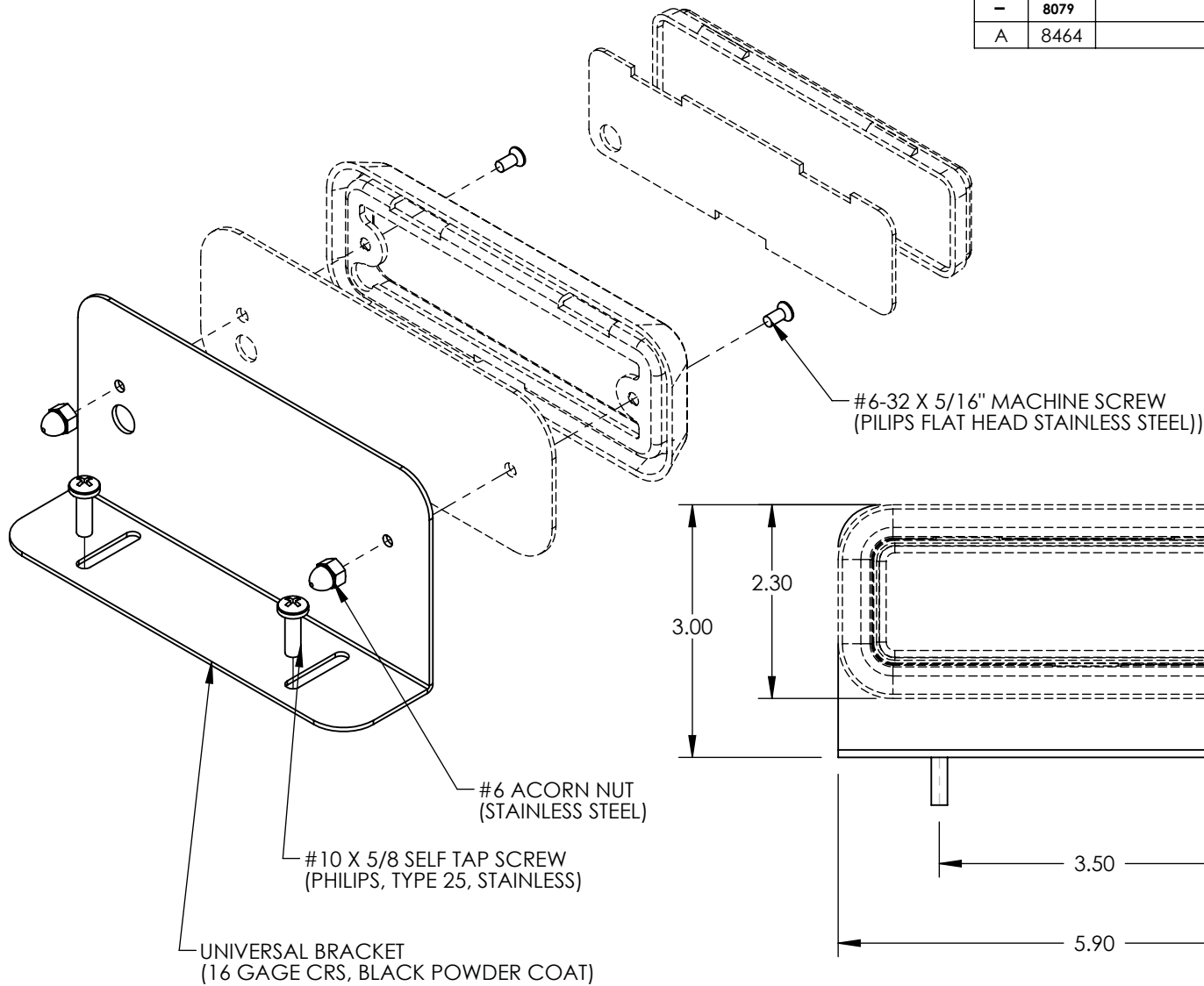

NOTES:

- 1) 5X7 POLY BAG (P30024-16)
- 2) BAG LABEL (PLAB21X2WHI)
- 3) INSTRUCTION SHEET (PLIT425)

UNLESS OTHERWISE SPECIFIED DIMENSIONS ARE IN INCHES TOLERANCES: ANGULAR: ± 2 DEG. .X ± .100 .XX ± .020 .XXX ± .005 .XXXX ± .001	DRAWN BY: MD DRAWING APPROVED BY ECR	STAR HEADLIGHT & LANTERN CO., INC. 455 Rochester St. Avon NY 14414 Ph:(585) 226-9500 Fax: (585) 226-2029	
	THE INFORMATION CONTAINED IN THIS DRAWING IS THE SOLE PROPERTY OF STAR HEADLIGHT & LANTERN CO., INC.. ANY REPRODUCTION IN PART OR AS A WHOLE WITHOUT THE WRITTEN PERMISSION OF STAR HEADLIGHT & LANTERN CO., INC. IS STRICTLY PROHIBITED.		MODEL: 274-DLXT-U TITLE: 274-DLXT-U MODEL DRAWING
RoHS COMPLIANT: Yes MATERIAL: N/A FINISH: N/A	DWG. NO. 274-DLXT-U		REV A
SCALE: 1:2		DO NOT SCALE FROM DRAWING	SHEET 1 OF 1